

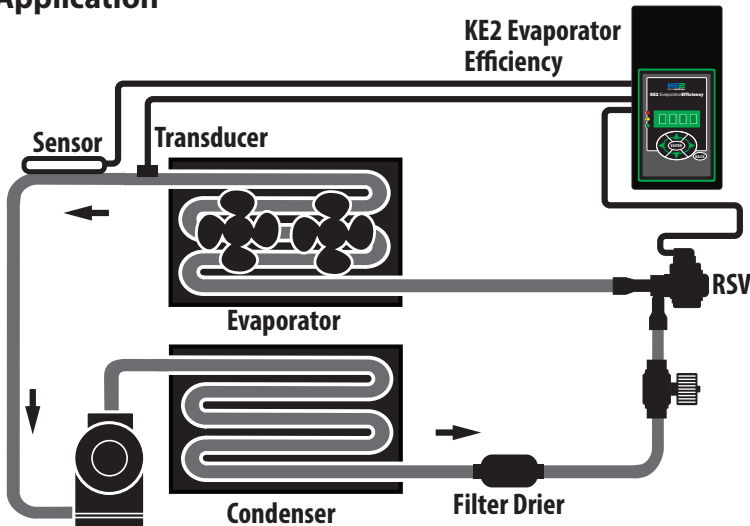

How to: Install the RSV Stepper Valve Electronic Expansion Valve

Application



Specifications RSV



Refrigerants:

R-22, R-134a, R-404A, R-407A, R-407C, R-407F, R-410A, R-507, R-422A, R-422D, R-438A, R-408A, R-409A, 448A, 449A, 450A, 513A



Oils:

mineral, POE, alkylbenzene



MRP: 600 psi (41 bar)



MAX: 140° F (60°C)

MIN: -22° F (-30°C)



12 Volt; Two-phase; Unipolar

Max. steps: 500

Steps per second: 30 to 90

Brazing

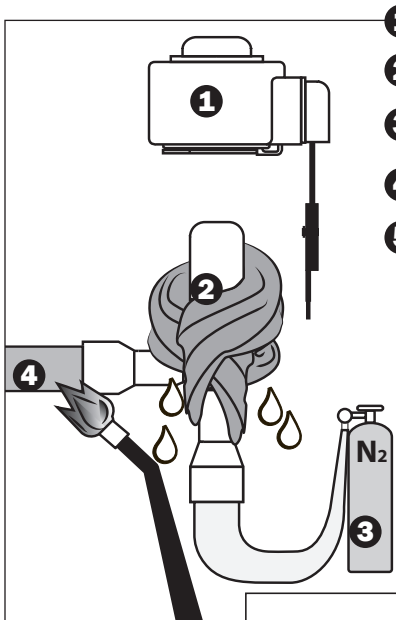

- 1 Remove stator from valve body
- 2 Wrap valve body in a wet cloth.
- 3 Use inert gas to purge the line.
- 4 Direct flame away from RSV
- 5 Install a filter drier in the liquid line, ahead of the RSV*.

**Installing a filter drier helps to prevent system contaminants from disrupting valve performance, and impeding the refrigerant flow. This general installation recommendation is widely accepted in the industry as best practice when installing electric or mechanical expansion valves.*

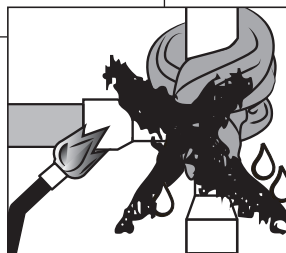

Mounting Direction

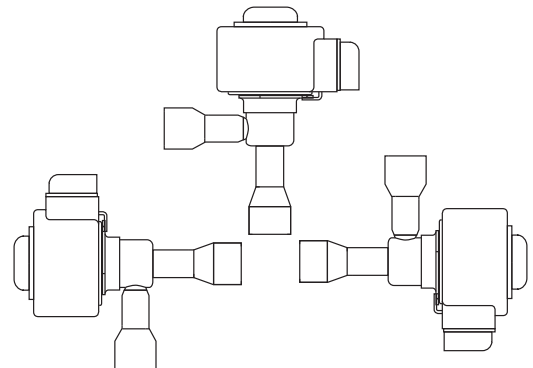

Wiring RSV to KE2 Evap or KE2 Temp + Valve Control

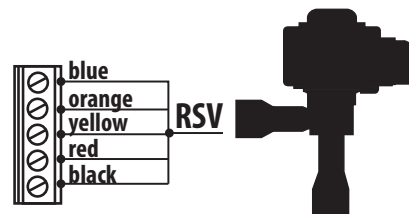



How to: Install the RSV Stepper Valve

Electronic Expansion Valve

Dimensions - Inches (mm)

RSV 100, 200, 300 Series

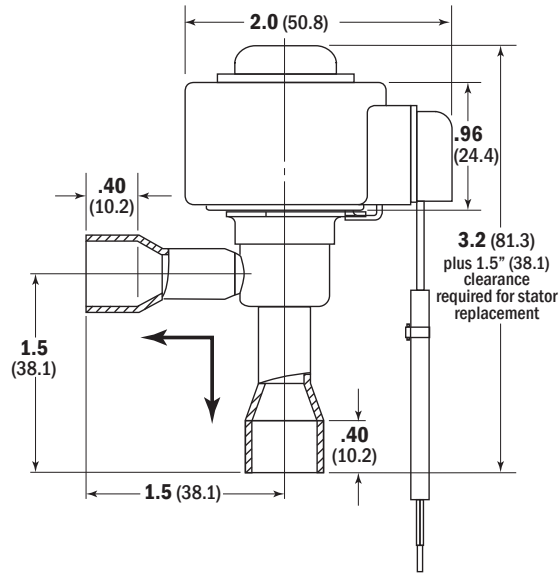

Dimensions - Inches (mm)

RSV 400, 500, 600 Series

